

NEOCLASSICO

MIRABILIA 12

MIRABILIA TIMBER 48

SPLENDIA 62



FIRMA LE VERE PORTE IN LEGNO MASSICCIO

RAFFINATA BELLEZZA

PUREZZA DELLE LINEE, UN DESIGN SEMPLICE E RAFFINATO E UNA SUPERFICIE LISCIA, QUASI VELLUTATA. QUESTE LE PECULIARITÀ DELLA COLLEZIONE MIRABILIA, UNA PORTA CHE VANTA I PIÙ NUMEROSI TENTATIVI DI IMITAZIONE E AMPI CONSENSI DA PARTE DEL PUBBLICO. UN NOME ELOQUENTE, SINTESI DI UN PRODOTTO SPECIALE CHE PERSONALIZZA CON STILE ED ELEGANZA QUALSIASI AMBIENTE, DAL CLASSICO AL MODERNO.

SOPHISTICATED BEAUTY CLEAN LINES, A SIMPLE REFINED DESIGN AND A SMOOTH, ALMOST VELVETY SURFACE. THESE ARE THE PECULIARITIES OF THE MIRABILIA COLLECTION, A DOOR OF WIDESPREAD SUCCESS AND THE MOST IMITATED. AN ELOQUENT NAME, THE SYNTHESIS OF A SPECIAL PRODUCT THAT PERSONALISES ANY SETTING, FROM CLASSIC TO MODERN, WITH STYLE AND ELEGANCE.

BEAUTE RAFFINÉE PURETÉ DES LIGNES, UN DESIGN SIMPLE, RAFFINÉ ET UNE SURFACE LISSE, PRESQUE VELOUTÉE. VOILÀ LES CARACTÉRISTIQUES DE LA COLLECTION MIRABILIA, LA PORTE LA PLUS IMITÉE ET PRISÉE PAR LE PUBLIC. UN NOM ELOQUENT, SYNTHÈSE D'UN PRODUIT SPÉCIAL QUI PERSONNALISE AVEC STYLE ET ÉLEGANCE TOUT INTÉRIEUR, DU CLASSIQUE AU MODERNE.

BELLEZA REFINADA LÍNEAS PURAS, DISEÑO SENCILLO Y ELEGANTE, SUPERFICIE LISA, CASI ATERCIOPELADA: ÉSTAS SON LAS CARACTERÍSTICAS QUE DISTINGUEN LA COLECCIÓN DE PUERTAS MIRABILIA, QUE CUENTA CON LA MAYOR CANTIDAD DE INTENTOS DE IMITACIÓN Y CON LA GRAN ADMIRACIÓN DEL PÚBLICO. UN NOMBRE ELOQUENTE, SÍNTESIS DE UN PRODUCTO ESPECIAL QUE PERSONALIZA CON ESTILO Y ELEGANCIA CUALQUIER TIPO DE AMBIENTE, DESDE EL CLÁSICO HASTA EL MODERNO.

RAFFINIERTE SCHÖNHEIT KLARE LINIENFÜHRUNG, EIN RAFFINIERT-EINFACHES DESIGN, UND EINE GLATTE, BEINAHE SAMTIGE OBERFLÄCHE SIND DIE BESONDERHEITEN DER KOLLEKTION MIRABILIA. EINE TÜR, DIE SICH GROSSER BELIEBTHEIT ERFREUT, UND SCHON OFT VERGEBLICH KOPIERT WURDE. EIN NAME, DER FÜR SICH SPRICHT, UND IN EINEM BEGRIFF DAS ZUM AUSDRUCK BRINGT, WAS DIESE TÜR SO BESONDERS MACHT: IHRE FÄHIGKEIT, JEDES AMBIENTE, VON KLASSISCH BIS MODERN, MIT STIL UND ELEGANZ ZU PERSONALISIEREN.

ИЗЫСКАННАЯ КРАСОТА ЧИСТОТА ЛИНИЙ, ПРОСТОЙ И ИЗЫСКАННЫЙ ДИЗАЙН, ГЛАДКАЯ, ПОЧТИ БАРХАТИСТАЯ ПОВЕРХНОСТЬ. ТАКОВЫ ХАРАКТЕРИСТИКИ КОЛЛЕКЦИИ ДВЕРЕЙ МИРАБИЛИА, КОТОРЫЕ ПОЛЬЗУЮТСЯ БОЛЬШИМ УСПЕХОМ У ПУБЛИКИ И ОЧЕНЬ ЧАСТО ПОДДЕЛЫВАЮТСЯ. ИХ КРАСНОРЕЧИВОЕ НАЗВАНИЕ ОПРЕДЕЛЯЕТ СПЕЦИАЛЬНОЕ ИЗДЕЛИЕ, ПРИДАЮЩЕЕ ШТРИХ СТИЛЯ И ЭЛЕГАНТНОСТИ ЛЮБОМУ ПОМЕЩЕНИЮ, КЛАССИЧЕСКОМУ ИЛИ СОВРЕМЕННОМУ.

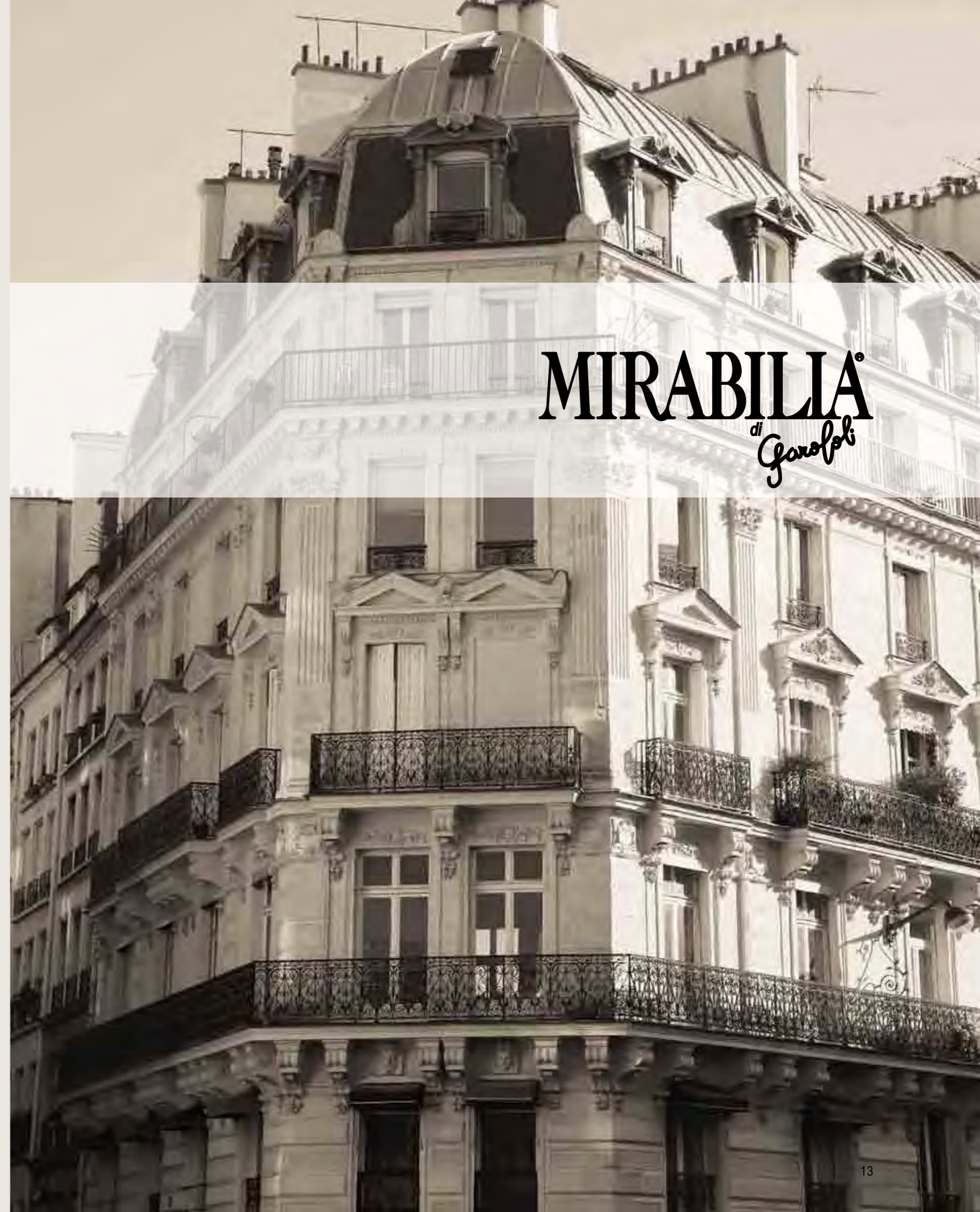

MIRABILIA[®]
di Garofoli



MOD. MIRABILIA EMI 6B
 PORTONE BLINDATO, CON PANNELLO, BIANCO LACCATO.
 SECURITY DOOR, WITH PANEL, WHITE LACQUER FINISH.
 PORTE BLINDÉE, AVEC PANNEAU, BLANC LAQUE.
 PUERTA BLINDADA, CON PANEL, LACADO BLANCO.
 GERANZERTE TÜR, MIT PANEEL, LACKIERT WEISS.
 БРОНИРОВАННАЯ ВХОДНАЯ ДВЕРЬ С ПАНЕЛЯМИ, БЕЛЫЙ ЛАКИРОВАННЫЙ ЦВЕТ.

MOD. EMI 6B
 PORTE A BATTENTE, LACCATO BIANCO.
 HINGED DOORS, WHITE LACQUER FINISH.
 PORTES A BATTANT, LAQUE BLANC.
 PUERTAS BATIENTES, LACADO BLANCO.
 DREHFLÜGELTÜREN, LACKIERT WEISS.
 РАСПАШНЫЕ ДВЕРИ, БЕЛЫЙ ЛАКИРОВАННЫЙ ЦВЕТ.



MOD. EMI 6B
PORTE A BATTENTE, LACCATO BIANCO.
HINGED DOORS, WHITE LACQUER FINISH.
PORTES A BATTANT, LAQUE BLANC.
PUERTAS BATIENTES, LACADO BLANCO.
DREHFLÜGELTÜREN, LACKIERT WEISS.
РАСПАШНЫЕ ДВЕРИ, БЕЛЫЙ ЛАКИРОВАННЫЙ ЦВЕТ.



MOD. EMI 6B
PORTE A BATTENTE, LACCATO BIANCO.
HINGED DOORS, WHITE LACQUER FINISH.
PORTES A BATTANT, LAQUE BLANC.
PUERTAS BATIENTES, LACADO BLANCO.
DREHFLÜGELTÜREN, LACKIERT WEISS.
РАСПАШНЫЕ ДВЕРИ, БЕЛЫЙ ЛАКИРОВАННЫЙ ЦВЕТ.





MOD. GALA 1B1V

PORTA A BATTENTE, LACCATO BIANCO CON VETRO MOLATO E INCISO LATO SATINATO.
HINGED DOOR, WHITE LACQUER WITH GROUND AND ETCHED GLASS, SATIN-FINISH SIDE.
PORTE À BATTANT, LAQUÉE BLANCHE AVEC VERRE TAILLÉ ET GRAVÉ CÔTÉ SATINÉ.
PUERTA BATIENTE, LAQUEADO BLANCO CON VIDRIO BISELADO Y TALLADO LADO SATINADO.
FLÜGELTÜR, WEISS LACKIERT MIT GESCHLIFFENEM UND GRAVIERTEM GLAS, SATINIERT.
РАСПАШНАЯ ДВЕРЬ, ЛАКИРОВКА БЕЛОГО ЦВЕТА, СТЕКЛО ШЛИФОВАННОЕ,
С ГРАВИРОВКОЙ С САТИНИРОВАННОЙ СТОРОНЫ.

MOD. DESTA 2B

PORTE A BATTENTE, LACCATO BIANCO.
HINGED DOOR, WHITE LACQUER FINISH.
PORTES A BATTANT, LAQUE BLANC.
PUERTAS BATIENES, LACADO BLANCO.
DREHFLÜGELTÜREN, LACKIERT WEISS.
РАСПАШНЫЕ ДВЕРИ, БЕЛЫЙ ЛАКИРОВАННЫЙ ЦВЕТ.



IL FASCINO
CHE DURA
PER SEMPRE:
MIRABILIA,
ICONA DI
STILE.

TIMELESS CHARM: MIRABILIA, AN ICON OF STYLE.

LE CHARME ETERNEL: MIRABILIA, ICONE DE STYLE.

EL ENCANTO ETERNO DE MIRABILIA, EMBLEMA DE ESTILO.

EWIGE FASZINATION: MIRABILIA, EINE STILIKONE.

ОЧАРОВАНИЕ НАВСЕГДА: MIRABILIA - ЭТО ОЛИЦЕТВОРЕНИЕ СТИЛЯ.

MOD. EMI 6B

PORTE A BATTENTE, LACCATO BIANCO.
HINGED DOORS, WHITE LACQUER FINISH.
PORTES A BATTANT, LAQUE BLANC.
PUERTAS BATIENDES, LACADO BLANCO.
DREHFLÜGELTÜREN, LACKIERT WEISS.
РАСПАШНЫЕ ДВЕРИ, БЕЛЫЙ ЛАКИРОВАННЫЙ ЦВЕТ.

MOD. GALA 1B1V

PORTA A BATTENTE, LACCATO BIANCO CON VETRO MOLATO E INCISO LATO SATINATO.
HINGED DOOR, WHITE LACQUER WITH GROUND AND ETCHED GLASS, SATIN-FINISH SIDE.
PORTE À BATTANT, LAQUÉE BLANCHE AVEC VERRE TAILLÉ ET GRAVÉ CÔTÉ SATINÉ.
PUERTA BATIENDE, LAQUEADO BLANCO CON VIDRIO BISELADO Y TALLADO LADO SATINADO.
FLÜGELTÜR, WEISS LACKIERT MIT GESCHLIFFENEM UND GRAVIERTEM GLAS AUF DER SATINIERTEN SEITE.
РАСПАШНАЯ ДВЕРЬ, ЛАКИРОВКА БЕЛОГО ЦВЕТА, СТЕКЛО ШЛИФОВАННОЕ, С ГРАВИРОВКОЙ С САТИНИРОВАННОЙ СТОРОНЫ.





MOD. RETA 10V

PORTA A BATTENTE, ANTA DOPPIA, LACCATO BIANCO. VETRO MOLATO LATO SATINATO.
HINGED DOUBLE DOOR, WHITE LACQUER WITH GROUND GLASS, SATIN-FINISH SIDE.
PORTE À BATTANT, DEUX VANTAUX, LAQUÉE BLANCHE. VERRE TAILLÉ CÔTÉ SATINÉ.
PUERTA BATIENTE, PUERTA DOBLE, LAQUEADO BLANCO. VIDRIO BISELADO LADO SATINADO.
FLÜGELTÜR, DOPPELFLÜGEL, WEISS LACKIERT. GESCHLIFFENES GLAS AUF DER SATINIERTEN SEITE.
РАСПАШНАЯ ДВЕРЬ, ДВОЙНАЯ СТВОРКА, ЛАКИРОВКА БЕЛОГО ЦВЕТА. СТЕКЛО ШЛИФОВАННОЕ С САТИНИРОВАННОЙ СТОРОНЫ.

MOD. EMI 6B

PORTE A BATTENTE, LACCATO BIANCO.
HINGED DOOR, WHITE LACQUERED FINISH.
PORTE A BATTANT, LAQUE BLANC.
PUERTA BATIENTE, LACADO BLANCO.
DREHFLÜGELTÜR, LACKIERT WEISS.
РАСПАШНАЯ ДВЕРЬ, БЕЛЫЙ ЛАКИРОВАННЫЙ ЦВЕТ.



MOD. RETA 10V

LACCATO BIANCO, 2 ANTE, CON VETRI MADRAS, MOLATI LATO SATINATO.
WHITE LACQUER, 2 DOORS, WITH MADRAS GLASS, GROUND SATIN-FINISH SIDE.
LAQUÉE BLANCHE, DEUX VANTAUX, AVEC VERRES MADRAS, TAILLÉS ET SATINÉS.
LAQUEADO BLANCO, 2 HOJAS, CON VIDRIOS MADRAS, BISELADOS LADO SATINADO.
WEISS LACKIERT, 2 FLÜGEL, MIT MADRAS-GLÄSERN, GESCHLIFFEN AUF DER SATINIERTEN SEITE.
ЛАКИРОВКА БЕЛОГО ЦВЕТА, 2 СТОВРКИ СО СТЕКЛАМИ «МАДРАС», ШЛИФОВАННЫЕ, С САТИНИРОВАННОЙ СТОРОНЫ.



MOD. LUTA 3B
PORTE A BATTENTE, LACCATO BIANCO.
HINGED DOOR, WHITE LACQUERED FINISH.
PORTE A BATTANT, LAQUE BLANC.
PUERTA BATIENTE, LACADO BLANCO.
DREHFLÜGELTÜR, LACKIERT WEISS.
РАСПАШНАЯ ДВЕРЬ, БЕЛЫЙ ЛАКИРОВАННЫЙ ЦВЕТ.

ARMADIATURA MOD. MIRIA
6 ANTE BIGNATE, LACCATO BIANCO, VERSIONE A BATTENTE.
6 ASHLAR PANNELLED DOORS, WHITE LACQUERED, HINGED VERSION.
6 BATTANTS ORNÉS DE BOSSAGE, LAQUE BLANC, VERSION A BATTANT.
6 HOJAS ALMOHADILLADAS, LACADO BLANCO, VERSION BATIENTE.
6 DREHFLÜGEL-KASSETTENTÜREN, LACKIERT WEISS.
6 РУСТОВАННЫХ СТВОРОК, БЕЛЫЙ ЛАКИРОВАННЫЙ ЦВЕТ, РАСПАШНАЯ МОДЕЛЬ.



GAROFOLI:
LA QUALITÀ CHE
SCEGLIETE PER
RACCHIUDERE
IL VOSTRO
UNIVERSO

GAROFOLI: A QUALITY CHOICE TO CIRCUMSCRIBE YOUR UNIVERSE.

GAROFOLI: LA QUALITE QUE VOUS CHOISISSEZ POUR RENFERMER VOTRE UNIVERS.

GAROFOLI: LA CALIDAD QUE SE ELIGE PARA CUSTODIAR EL PROPIO UNIVERSO.

GAROFOLI: SCHÜTZEN SIE IHRE GANZ PERSÖNLICHEN DINGE MIT QUALITÄT.

GAROFOLI: ВЫБРАННОЕ ВАМИ КАЧЕСТВО ДЛЯ ХРАНЕНИЯ ВАШЕГО МИРА.

ARMADIATURA MOD. MIRIA

6 ANTE BUGNATE, LACCATO BIANCO, VERSIONE A BATTENTE.
6 ASHLAR PANELLED DOORS, WHITE LACQUERED, HINGED VERSION.
6 BATTANTS ORNES DE BOSSAGE, LAQUE BLANC, VERSION A BATTANT.
6 HOJAS ALMOHADILLADAS, LACADO BLANCO, VERSIÓN BATIENTE.
6 DREHFLÜGEL-KASSETTENTÜREN, LACKIERT WEISS.
6 РУСТОВАННЫХ СТВОРОК, БЕЛЫЙ ЛАКИРОВАННЫЙ ЦВЕТ. РАСПАШНАЯ МОДЕЛЬ.





GAROFOLI:
LE FORME
DEL BEL VIVERE
CHE ESALTANO
LA VOSTRA
CASA

GAROFOLI: BEAUTIFUL SHAPES TO ENHANCE YOUR HOME.

GAROFOLI: LES FORMES DE L'ART DE VIVRE QUI METTENT EN AVANT VOTRE MAISON.

GAROFOLI: LOS SIGNOS DEL BIENESTAR QUE DESTACAN VUESTRO HOGAR.

GAROFOLI: SCHÖNE TÜREN, FÜR EIN SCHÖNERES ZUHAUSE UND EIN SCHÖNERES LEBEN.

GAROFOLI: ФОРМЫ КРАСОТЫ ПОДЧЕРКИВАЮТ ЦЕННОСТЬ ВАШЕГО ДОМА.

MOD. AURA

PORTA LISCIA, LACCATA BIANCA CON INSERIMENTO SPECCHIO NEL LATO INTERNO.
PLAIN DOOR, WHITE LACQUERED WITH MIRROR INSERT ON THE INNER SIDE.
PORTE LISSE, LAQUEE BLANCHE AVEC INSERTION MIROIR SUR LE COTE INTERIEUR.
PUERTA LISA, LACADO BLANCO CON APLICACION DE ESPEJO DEL LADO INTERNO.
GLATTE TÜR, LACKIERT WEISS, MIT SPIEGEL AN DER INNENSEITE.
ГЛАДКАЯ БЕЛАЯ ЛАКИРОВАННАЯ ДВЕРЬ, ЗЕРКАЛО ВСТАВЛЕНО С ВНУТРЕННЕЙ СТОРОНЫ.



MOD. LUTA 3B
LACCATA BIANCO.
WHITE LACQUERED.
LAQUEE BLANC.
LACADO BLANCO.
LACKIERT WEISS.
БЕЛАЯ ЛАКИРОВКА.



GAROFOLI: LA PORTA CHE CAMBIA LA CASA CON LA RAZIONALITÀ DELLE SOLUZIONI TECNICHE

GAROFOLI: A DOOR THAT CHANGES YOUR HOME WITH THE LOGIC OF ITS TECHNICAL SOLUTIONS.

GAROFOLI: LA PORTE QUI TRANSFORME LA MAISON AVEC LA RATIONALITE DES SOLUTIONS TECHNIQUES.

GAROFOLI: LA PUERTA QUE CAMBIA LA CASA CON LA RACIONALIDAD DE LAS SOLUCIONES TÉCNICAS.

GAROFOLI: DIE TÜR, DIE DAS AMBIENTE MIT DER RATIONALITÄT DER TECHNISCHEN LÖSUNGEN VERÄNDERT.

GAROFOLI: ДВЕРЬ МЕНЯЕТ ОБЛИК ДОМА РАЦИОНАЛЬНОСТЬЮ ТЕХНИЧЕСКИХ РЕШЕНИЙ.

MOD. BILA 1V
LACCATO BIANCO VETRO LAIN AZZURRO.
WHITE LACQUER, AZURE LAIN GLASS.
LAQUE BLANC VERRE LAIN BLEU.
LACADO BLANCO CON VIDRIO LAIN AZUL CLARO.
LACKIERT WEISS, GLAS LAIN AZUR.
ЦВЕТ БЕЛЫЙ ЛАКИРОВАННЫЙ, СТЕКЛО LAIN ГОЛУБОГО ЦВЕТА.



LA BELLEZZA
È NEL DETTAGLIO,
L'ELEGANZA NELLA
RAFFINATA SEMPLICITÀ

ITS BEAUTY IS IN THE DETAILS, ITS ELEGANCE, IN THE SOPHISTICATED SIMPLICITY.

LA BEAUTE EST DANS LES DETAILS, L'ELEGANCE DANS LA SIMPLICITE RAFFINEE.

LA BELLEZA DE LOS DETALLES, LA ELEGANCIA DE LA SENCILLEZ.

DIE SCHÖNHEIT LIEGT IM DETAIL, DIE ELEGANZ IN DER RAFFINIERTEN SCHLICHTHEIT.

КРАСОТА КРОЕТСЯ В ДЕТАЛЯХ, ЭЛЕГАНТНОСТЬ - В ИЗЫСКАННОЙ ПРОСТОТЕ.

MOD. DESTA 2B
LACCATA BIANCO.
WHITE LACQUERED.
LAQUEE BLANC.
LACADO BLANCO.
LACKIERT WEISS.
БЕЛАЯ ЛАКИРОВКА.





DESTA 2B



LUTA 3B



MESIA 3B99



RETA 10V



PLEA 2BARCO



UTE 10VARCO



ERIA 4B



EMI 6B



ENIA 2B98



DENA 2BC



SIRA 1B1VC



MIA 1BARCO



ULMA 1B6VARCO



GALA 1B1V



CLEO 2B1V



PULA 2B01V



KAMI 3V99



VALIA 5V



SINTRA 2V98



NITA 2B2V



ZETI 10VC



CELSA 1B



QUALIA 1VC



AFRA 1B6V



EDER 2B6V



OLISSIA 3BE



NIVA 1VARCO



MALVA 1B1VARCO



VERDISIA
1B 1V 2005



BILA 1V



AURA PORTA
LISCIA



1M2007



TEO 1/B/6/V/C



TINA 1V2001



ISA 1TV

Colori laccati . Lacquer colours . Coloris laqués . Colores lacados
Lackierte Farben . Цвета лакировки



Colori RAL a richiesta . Colori RAL a richiesta . RAL colours on request
Couleurs RAL sur demande . Colores RAL bajo pedido . RAL-Farben auf Anfrage
Цвета по шкале RAL по заказу

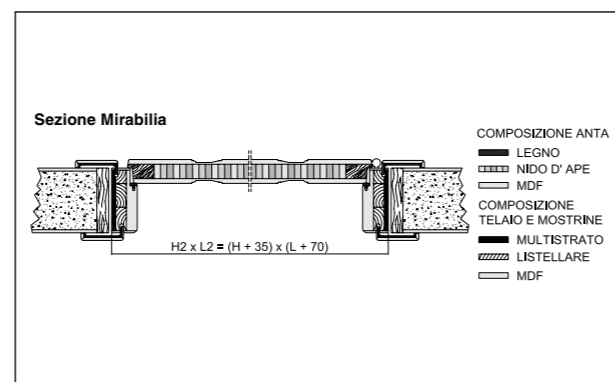

NEOCLASSICO RICERCATO

IL VOLTO NUOVO DEL LEGNO MASSICCIO, OSSIA UNA PORTA CLASSICA REINTERPRETATA IN MODO ORIGINALE. L'INCONSUETA LINEARITÀ È COMBINATA CON INCISIONI E BUGNATI ESEGUITI IN PREVALENZA SU LEGNI CHIARI. IL RISULTATO È UNA COLLEZIONE LEGGERA E FORTE ALLO STESSO TEMPO, CAPACE DI ARRICCHIRE DEL FASCINO E DEL CALORE DEL LEGNO MASSICCIO, ANCHE L'AMBIENTE PIÙ MODERNO.

REFINED NEOCLASSICISM THE NEW LOOK OF SOLID WOOD, AN ORIGINAL REINTERPRETATION OF THE CLASSIC DOOR. THE UNUSUAL LINEARITY IS COMBINED WITH ENGRAVING AND ASHLARED PANELS MOSTLY ON LIGHT COLOURED WOODS. THE RESULT IS A LIGHT, YET STRONG COLLECTION CAPABLE OF ADDING THE CHARM AND WARMTH OF SOLID WOOD TO EVEN THE MOST MODERN SETTING.

NEOCLASSIQUE RECHERCHE LE NOUVEAU VISAGE DU BOIS MASSIF: UNE PORTE CLASSIQUE REVISITEE AVEC ORIGINALITE. L'INSOLITE LINEARITE SE MARIE AVEC LES INCISIONS ET LES BOSSAGES REALISES PRINCIPALEMENT SUR DES BOIS CLAIRS. LE RESULTAT EST UNE COLLECTION A LA FOIS LEGERE ET FORTE, CAPABLE D'APPORTER LE CHARME ET LA CHALEUR DU BOIS MASSIF A L'INTERIEUR LE PLUS MODERNE.

NEOCLÁSICO SOFISTICADO LA NUEVA IMAGEN DE LA MADERA MACIZA: UNA PUERTA CLÁSICA REINTERPRETADA DE MANERA ORIGINAL. LA INSÓLITA LINEALIDAD COMBINADA CON LABRADOS Y ALMOHADILLADOS, PREFERENTEMENTE EN MADERAS CLARAS. EL RESULTADO ES UNA COLECCIÓN LIGERA Y SÓLIDA A LA VEZ, CAPAZ DE EXALTAR EL ENCANTO Y LA CALIDEZ DE LA MADERA MACIZA HASTA EN LOS AMBIENTES MÁS MODERNOS.

EDLE KLASSIK IN NEUER OPTIK DAS NEUE GESICHT VON MASSIVEM HOLZ - EINE KLASSISCHE TÜR IN AKTUELLER INTERPRETATION. DIE UNGEWÖHNLICHE LINEARITÄT HARMONIIERT PERFEKT MIT DEN KASSETTEN UND FRÄSUNGEN, VOR ALLEM AUF HELLEM HOLZ. DAS RESULTAT IST EINE KOLLEKTION, DIE LEICHT UND STARK ZUGLEICH IST, UND AUCH DAS MODERNSTE AMBIENTE MIT DER ZEITLOSEN FASZINATION UND WÄRME VON MASSIVEM HOLZ BEREICHERT.

ИЗЫСКАННЫЙ НЕОКЛАССИЧЕСКИЙ СТИЛЬ НОВОЕ ЛИЦО МАССИВНОГО ДЕРЕВА, ТО ЕСТЬ, ОРИГИНАЛЬНОЕ ПЕРЕОСМЫСЛЕНИЕ КЛАССИЧЕСКОЙ ДВЕРИ. НЕОБЫЧНАЯ ЛИНЕЙНОСТЬ СОЧЕТАЕТСЯ С РЕЗЬБОЙ И РУСТАМИ, ВЫПОЛНЕННЫМИ В ОСНОВНОМ НА ДЕРЕВЕ В СВЕТЛЫХ ТОНАХ. В РЕЗУЛЬТАТЕ ПОЛУЧАЕТСЯ ЛЕГКАЯ, И В ТО ЖЕ ВРЕМЯ ВНУШИТЕЛЬНАЯ КОЛЛЕКЦИЯ, СПОСОБНАЯ ОБОГАЩАТЬ ОЧАРОВАНИЕМ И ТЕПЛОМ МАССИВНОГО ДЕРЕВА ДАЖЕ САМЫЙ СОВРЕМЕННЫЙ ИНТЕРЬЕР.

MIRABILIA[®]
TIMBER
di Garofoli

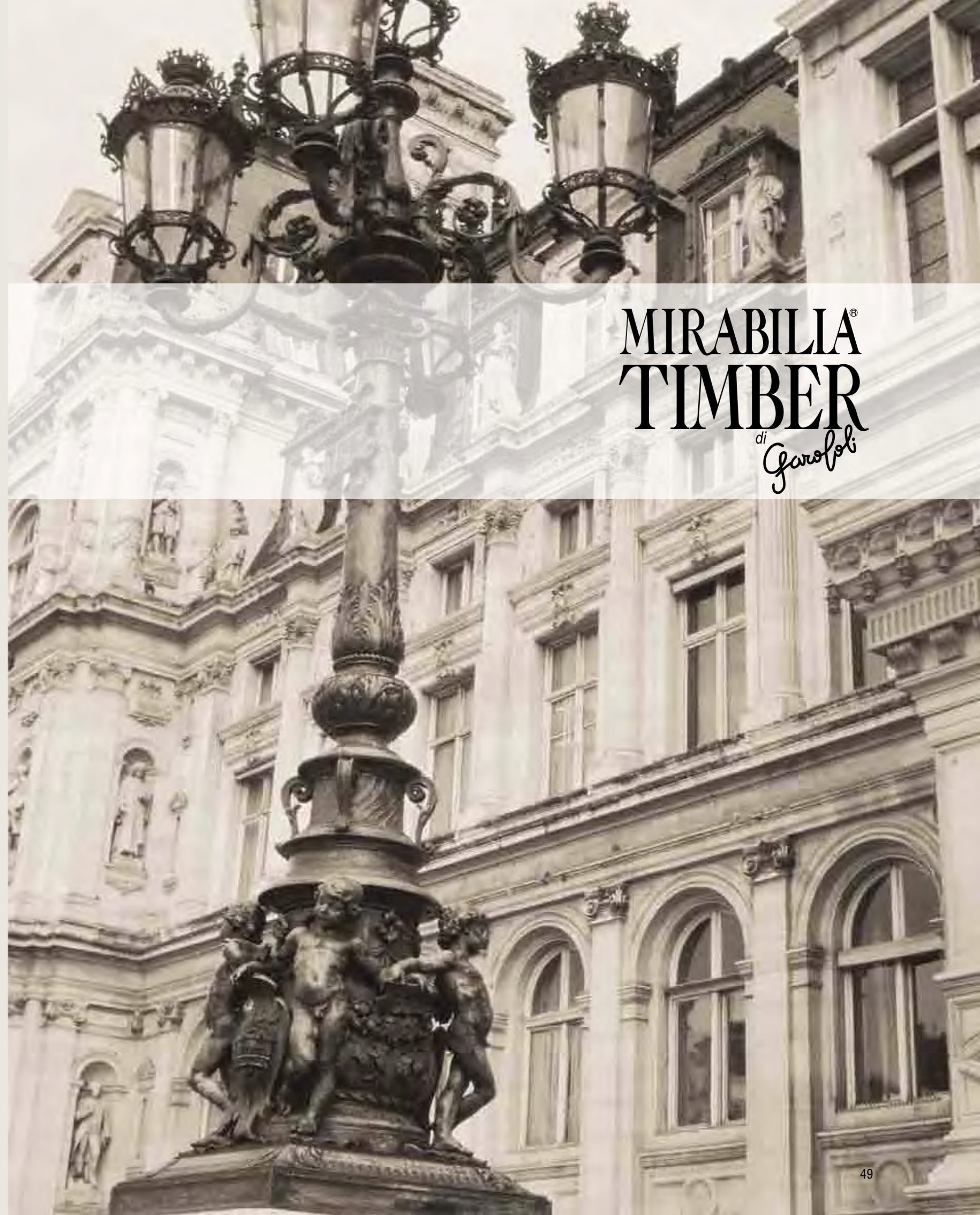

MOD. EBLA 2B
ARTE POVERA.
ARTE POVERA.
ARTE POVERA.
ARTE POBRE.
ARTE POVERA.
ARTE POVERA.



L' ELEGANZA DEL LEGNO MASSICCIO: PER CHI CHIEDE QUALITÀ, SOLIDITÀ, CARATTERE.

THE ELEGANCE OF SOLID WOOD: FOR THOSE WHO WANT QUALITY, SOLIDITY, CHARACTER.

L'ELEGANCE DU BOIS MASSIF: POUR CEUX QUI RECHERCHENT QUALITE, SOLIDITE, CARACTERE.

LA ELEGANCIA DE LA MADERA MACIZA: PARA QUIENES EXIGEN CALIDAD, SOLIDEZ Y CARÁCTER.

MASSIVES HOLZ – ELEGANT, HOCHWERTIG, ROBUST UND AUSDRUCKSSTARK.

ЭЛЕГАНТНОСТЬ МАССИВНОГО ДЕРЕВА: ДЛЯ ТЕХ, КОМУ НУЖНЫ КАЧЕСТВО, ПРОЧНОСТЬ, ХАРАКТЕР.

MOD. LUMMA 2BARCO
ASCERRY SCURO.
DARK ASCERRY.
ASCERRY FONCE.
ASCERRY OSCURO.
ASCERRY DUNKEL.
АМЕРИКАНСКАЯ ВИШНЯ ТЕМНАЯ.





MOD. ASSUR 2BC
ASCERRY SCURO.
DARK ASCERRY.
ASCERRY FONCE.
ASCERRY OSCURO.
ASCERRY DUNKEL.
АМЕРИКАНСКАЯ ВИШНЯ ТЕМНАЯ.



EBLA 2B



ZUBI 1B1V



BASRA 1B6V



KLISSIA 3B2005



KUTA 2B6V



ASSUR 2BC



DUGA 1B1VC



AKKAD 1B6VC



VESSUA 1B1V2005



GEBEL 4B



MENUA 6B



URUK 2B1V



LUMMA 2BARCO



NANNIA
1B1VARCO



KUARA
1B6VARCO



URSU PORTA
LISCIA



URA 1V2001



DARA 1TV



1M2007



EBLA 2B



ZUBI 1B1V



BASRA 1B6V



KLISSIA 3B2005



VESSUA 1B1V2005



GEBEL 4B



MENUA 6B



URUK 2B1V

Colori legni . Colours . Coloris . Colores . Farben . Цвета

ASCHERRY CHIARO LIGHT ASCHERRY ASCHERRY CLAIR ASCHERRY CLARO ASCHERRY HELL АМЕРИКАНСКАЯ ВИШНЯ СВЕТЛАЯ	ASCHERRY SCURO DARK ASCHERRY ASCHERRY SOMBRE ASCHERRY OSCURO ASCHERRY DUNKEL АМЕРИКАНСКАЯ ВИШНЯ ТЕМНАЯ	ASCHERRY NATURALE NATURAL ASCHERRY ASCHERRY NATUREL ASCHERRY NATURAL ASCHERRY NATURAL АМЕРИКАНСКАЯ ВИШНЯ НАТУРАЛЬНАЯ	ARTE POVERA ARTE POVERA ARTE POVERA ARTE POVERA ARTE POVERA ARTE POVERA

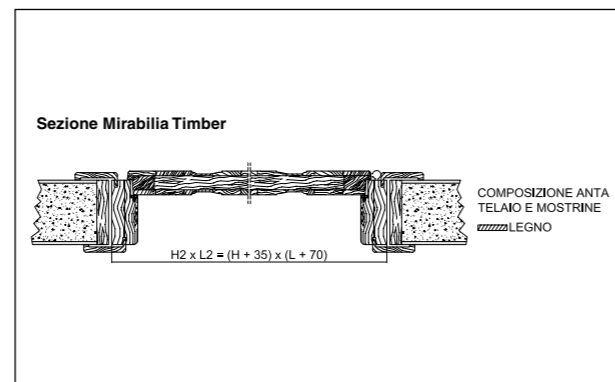



KUTA 2B6V



ASSUR 2BC



DUGA 1B1VC



AKKAD 1B6VC



URA 1V2001



DARA 1TV



1M2007



LUMMA 2BARCO



NANNIA
1B1VARCO



KUARA
1B6VARCO



URSU PORTA
LISCIA

Colori legni . Colours . Coloris . Colores . Farben . Цвета

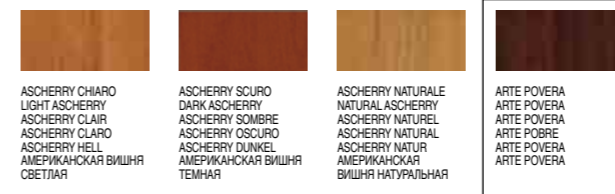

Sezione Mirabilia Timber

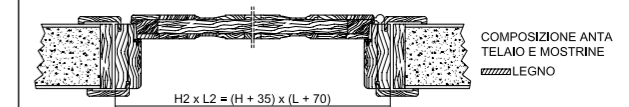

SEMPLICE ELEGANZA

UNA PORTA COSTRUITA INTERAMENTE IN LEGNO CHE AFFASCINA IMMEDIATAMENTE PER LA MORBIDEZZA DELLE SUE LINEE E L'ASSENZA DI SPIGOLI. LE SUE FORME, DOLCI E ROTONDE, DONANO CALORE A QUALSIASI AMBIENTE, PERSONALIZZANDOLO CON GUSTO. UNA COLLEZIONE UNICA CHE CONFERMA LA GRANDE ATTENZIONE DI GAROFOLI PER I DETTAGLI.

SIMPLE ELEGANCE A DOOR ENTIRELY CONSTRUCTED IN WOOD THAT IMMEDIATELY CHARMS WITH THE SOFTNESS OF ITS LINES AND THE ABSENCE OF SHARP CORNERS. ITS SOFT, ROUNDED CURVES ADD WARMTH TO ANY ROOM AND PERSONALISE IT WITH TASTE. A UNIQUE COLLECTION THAT CONFIRMS GAROFOLI'S GREAT ATTENTION TO DETAIL.

ELEGANCE SIMPLE PORTE ENTIEREMENT EN BOIS QUI SEDUIT IMMEDIATEMENT PAR LA SOUPLISSE DE SES LIGNES ET PAR L'ABSENCE D'ARETES. SES FORMES, DOUCES ET ARRONDIES, APPORTENT CHALEUR ET PERSONNALISENT AVEC GOUT TOUT INTERIEUR. UNE COLLECTION UNIQUE QUI CONFIRME L'ATTENTION PORTEE PAR GAROFOLI AUX DETAILS.

SENCILLA ELEGANCIA PUERTA COMPLETAMENTE DE MADERA QUE ENCANTA DE INMEDIATO POR LA SUAVIDAD DE SUS LINEAS Y LA AUSENCIA DE ARISTAS VIVAS. SUS FORMAS SUAVES Y REDONDEADAS BRINDAN CALIDEZ A CUALQUIER AMBIENTE, APORTANDO UN GUSTO PERSONAL. UNA COLECCIÓN ÚNICA QUE CONFIRMA LA GRAN ATENCIÓN DE GAROFOLI POR LOS DETALLES.

SCHLICHTE ELEGANZ EIN ZUR GÄNZE AUS HOLZ GEFERTIGTE TÜR, DIE NICHT NUR AUF DEN ERSTEN BLICK MIT IHREN SANFTEN FORMEN FASZINIERT. EINE TÜR, DIE MIT IHREM SOFTEN DESIGN EIN ANGENEHMES GEFÜHL VON WOHLNICHKEIT VERMITTELT, UND JEDES AMBIENTE MIT GESCHMACK PERSONALISIERT. EINE AUSSERGEWÖHNLICH SCHÖNE KOLLEKTION, MIT DER FÜR GAROFOLI TYPISCHEN LIEBE ZUM DETAIL.

ПРОСТАЯ ЭЛЕГАНТНОСТЬ ЭТА ДВЕРЬ, ПОЛНОСТЬЮ ВЫПОЛНЕННАЯ ИЗ ДЕРЕВА, НЕМЕДЛЕННО ЗАВОРАЖИВАЕТ МЯГКОСТЬЮ СВОИХ ЛИНИЙ И ОТСУТСТВИЕМ ОСТРЫХ УГЛОВ. ЕЕ МЯГКИЕ И ОКРУГЛЫЕ ФОРМЫ ВНОСЯТ ТЕПЛО В ЛЮБОЕ ПОМЕЩЕНИЕ, ПРИДАВАЯ ЕМУ ИНДИВИДУАЛЬНЫЙ ХАРАКТЕР СО ВКУСОМ. ЭТА УНИКАЛЬНАЯ КОЛЛЕКЦИЯ ПОДТВЕРЖДАЕТ БОЛЬШОЕ ВНИМАНИЕ, КОТОРОЕ КОМПАНИЯ GAROFOLI УДЕЛЯЕТ ДЕТАЛЯМ.



MOD. BIRKA 2PA
NOCE.
WALNUT.
NOYER.
NOGAL.
NUSSBAUM.
OPEX.





MOD. KORBA 1PA1V

COLORE ARTE POVERA, VETRO MADRAS, MOLATO
E INCISO LATO LISCIO.
ARTE POVERA COLOUR, MADRAS GLASS,
GROUND AND ETCHED, SMOOTH SIDE.
COULEUR ART PAUVRE, VERRE MADRAS,
TAILLÉ ET GRAVÉ CÔTÉ LISSE.
COLOR ARTE POBRE, VIDRIO MADRAS, BISELADO Y TALLADO LADO LISO.
FARBE ARTE POVERA, MADRAS-GLAS, GESCHLIFFEN
UND GRAVIERT AUF DER GLATTEN SEITE.
ЦВЕТ СТАРОГО ДЕРЕВА, СТЕКЛО «МАДРАС», ШЛИФОВАННОЕ,
С ГРАВИРОВКОЙ С ГЛАДКОЙ СТОРОНЫ.

MOD. BIRKA 2PA

COLORE ARTE POVERA.
ARTE POVERA.
COLORIS ARTE POVERA.
COLOR ARTE POBRE.
FARBE ARTE POVERA.
ЦВЕТ ARTE POVERA.

LO STILE NON È
OSTENTAZIONE,
È GUSTO
E PERSONALITÀ.

STYLE IS NOT OSTENTATION; IT IS TASTE AND PERSONALITY.

LE STYLE N'EST PAS OSTENTATION, LE STYLE EST GOUT ET PERSONNALITE.

EL ESTILO NO ES OSTENTACIÓN, SINO GUSTO Y PERSONALIDAD.

UNAUFDRINGLICH STILVOLL, MIT GESCHMACK UND PERSÖNLICHKEIT.

СТИЛЬ - ЭТО НЕ САМОЦЕЛЬ, А ВКУС И ИНДИВИДУАЛЬНОСТЬ.

MOD. CATARIA 3V97

DARK CHERRY, VETRO TRASPARENTE CON RIGHE BIANCHE SERIGRAFATE.
DARK CHERRY, CLEAR GLASS WITH WHITE SILK-SCREENED STRIPES.
DARK CHERRY, VERRE TRANSPARENT AVEC RAYURES BLANCHES SERIGRAPHIÉES.
DARK CHERRY, VIDRIO TRANSPARENTE CON RAYAS BLANCAS EN SERIGRAFÍA.
DARK CHERRY, DURCHSICHTIGES GLAS MIT WEISSEN LINIEN AUS SIEBDRUCK.
ЦВЕТ ТЕМНАЯ ВИШНЯ, СТЕКЛО ПРОЗРАЧНОЕ, С БЕЛЫМИ ПОЛОСКАМИ ТРАФАРЕТНОЙ ПЕЧАТИ.



PORTE GAROFOLI IN LEGNO MASSICCIO: NATURALMENTE BELLE.

GAROFOLI DOORS IN SOLID WOOD: NATURALLY BEAUTIFUL.

DES PORTES GAROFOLI EN BOIS MASSIF: NATURELLEMENT BELLES.

PUERTAS GAROFOLI DE MADERA MACIZA: BELLEZA NATURAL.

GAROFOLI-TÜREN AUS VOLLHOLZ: NATÜRLICH SCHÖN.

ДВЕРИ GAROFOLI ИЗ МАССИВНОГО ДЕРЕВА - ЕСТЕСТВЕННАЯ КРАСОТА.

MOD. MIAMA 1PA
NOCE.
WALNUT.
NOYER.
NOGAL.
NUSSBAUM.
OPEX.





MOD. SUPRA 5V

SCORREVOLE IN NOCE, VETRO TRASPARENTE
CON RIGHE BIANCHE SERIGRAFATE.
WALNUT SLIDING DOOR, CLEAR GLASS WITH WHITE
SILK-SCREENED STRIPES.
COULISSANTE COULEUR NOYER, VERRE TRANSPARENT
AVEC RAYURES BLANCHES SERIGRAPHIÉES.
CORREDIZA DE NOGAL, VIDRIO TRANSPARENTE CON
RAYAS BLANCAS EN SERIGRAFIA.
SCHIEBETÜR AUS NUSS, DURCHSICHTIGES GLAS
MIT WEISSEN LINIEN AUS SIEBDRUCK.
РАЗДВИЖНАЯ, ИЗ ОРЕХА, СТЕКЛО ПРОЗРАЧНОЕ,
С БЕЛЫМИ ТРАФАРЕТНЫМИ ПОЛОСКАМИ.



MIAMA 1PA



BIRKA 2PA



SIARA 3PA



CABLA 3PA97



CUSCUTA 2PA97



ARNIKA 4PA



VISIA 1VS



KORBA 1PA1V



ELENIA 6PA



TRUMA 5PA



IRMA 1PAC



ALTEA 2PAC



KUNTA 3V



CATARIA 3V97



SUPRA 5V



LANDIA 1VCS



PERKA 1PA1VC



PIALA 2V97



BOSIA 2PA2V



PELTA 12VCS



ESERIA 1TV



1M2007



FRIA 1PA9VC



BRIONIA 12VS



LOTIA 1PA9V



ELISIA 1V2001

Colori legni . Colours . Coloris . Colores . Farben . Цвета

DARK CHERRY DARK CHERRY DARK CHERRY DARK CHERRY DARK CHERRY ВИШНЯ ТЕМНА	NOCE WALNUT NOYER NOGAL NUSSBAUM ОРЕХ	PERO PEAR WALNUT NOYER POIRIER NOGAL PERAL BIRNBAUM ГРУША	ARTE POVERA ARTE POVERA ARTE POVERA ARTE POBRE ARTE POVERA ARTE POVERA

